

Operation Manual

Version 1.1

Accuris™ SmartSeal™

Semi-Automated Plate Sealer

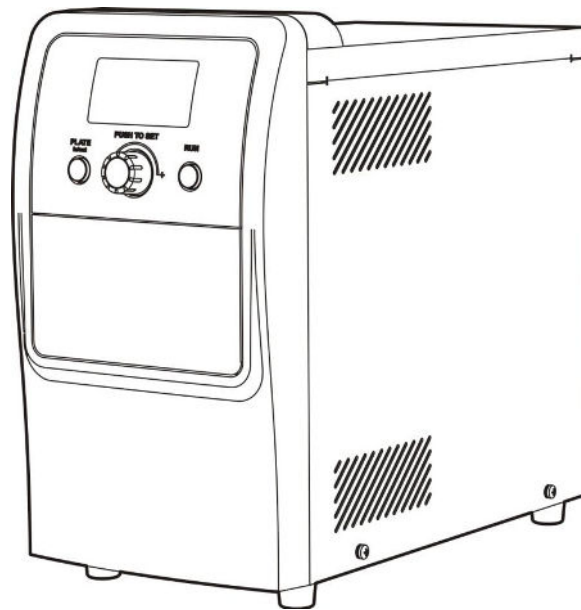

For Research Use Only



Foreword

Thank you for purchasing the Accuris SmartSeal Semi-Automated Plate Sealer. This manual contains important information about the function and proper operation of this instrument. Please read this manual thoroughly before operating the plate sealer.

Please check that the instrument received matches the local voltage requirements. The packaging should contain the plate sealer, this manual, a power cord, the standard plate adapter, PCR plate adapter and a metal seal holder. Save all packaging until the unit has used and found to be operating properly.

If the package has been damaged in transit, please keep all packaging and report the damage to the transportation carrier ASAP.

Accuris Instruments, a division of Benchmark Scientific can be contacted by phone at 908 769-5555 or email info@benchmarkscientific.com.

Safety Warnings and Guidelines

1. Important safety information:

Before operating the plate sealer, please read this manual thoroughly.



Serious burns or electric shock may occur from improper operation of this instrument. Read the guidelines and instructions in this manual and follow all safety precautions. All users should be instructed on proper operation.

2. Security:

The operation, maintenance and repair of the instrument should comply with the basic guidelines and warnings below. Failure to follow these guidelines may result in unsafe operation or shorten the life of the instrument.



This product is for routine, indoor use and conforms to Standard GB9706.1 (Class I, B type).



Before using the device, read the manual carefully. This unit is designed for use in laboratory environments. The device must be used by skilled personnel with the appropriate training.



Do not open or attempt to repair the instrument as this may cause serious harm to the operator and may void the warranty. If the instrument is not working properly, please contact the manufacturer for repair.



Before powering the instrument on, check that the voltage rating on the back panel matches that of the local supply.

If the power cord becomes damaged, replace it with the same IEC-320 power cable.

Be sure that the cord is inserted completely into both the instrument and power receptacle. Turn off the power on the back of the instrument before disconnecting the plug. When disconnecting from the receptacle, pull firmly on the plug. Do not pull on the power cord.



The heating plate can be very hot. Do not attempt to touch the heating plate or any internal parts while the unit is turned on. Remove plates from the drawer carefully.



The instrument should be located on a stable bench that is not in direct contact with sunlight. It should not be located nearby any water sources or instruments that produce heat, such as refrigerators, freezers, incubators, etc. There should be good airflow with no corrosive gas sources or strong magnetic fields nearby. Do not block the air vent on the instrument. If multiple instruments are side by side, they should be at least 50cm apart.



Power off the instrument when finished working. If it will not be used for a long time, unplug the unit and cover it with a cloth to protect from dust.



Unplug the unit immediately and contact the manufacturer if any of the following occur:

- The instrument gets wet
- There is an abnormal smell or sound
- The instrument has been dropped or the outer shell has been damaged
- The function of the instrument has obviously changed

3. The maintenance of instrument

The only routine maintenance required is to keep the unit clean. The heating plate platen can be cleaned with a soft cloth dipped in alcohol. The case can be cleaned with a soft cloth and 70% isopropyl alcohol.

4. After Service

a) Warranty Content

The SmartSeal is covered by a 2-year warranty. Contact the manufacturer for warranty service.

b) Warranty Scope

The warranty covers all repairs and breakdowns during normal operation. If the unit is not maintained, used and operated under the conditions described in this manual, the warranty may be void. The warranty does not cover damage caused by unauthorized repairs and/or modifications.

CONTENTS

CHAPTER 1	INTRODUCTION	1
CHAPTER 2	SPECIFICATIONS	2
1.	NORMAL OPERATION CONDITIONS:	2
2.	THE BASIC PARAMETERS AND CHARACTERISTICS	2
CHAPTER 3	BASIC INSTRUCTIONS	3
1.	STRUCTURE OVERVIEW	3
2.	OPERATION PANEL	4
3.	DISPLAY	4
CHAPTER 4	OPERATION GUIDE	5
1.	SETTING SEAL PARAMETERS	5
2.	SEAL OPERATION	6
3.	CLEANING THE HEATED PLATEN	6
4.	ADDITIONAL IMPORTANT INFORMATION	8
CHAPTER 5	TROUBLESHOOTING GUIDE	9
PROBLEMS AND ACTIONS		9
ANNEX:	WIRING DIAGRAM	10

Chapter 1 Introduction

The Accuris SmartSeal Plate Sealer is a semi-automatic thermal sealer which is ideal for the low to medium throughput laboratory that requires uniform and consistent sealing of micro-plates.

Unlike a manual plate sealer, the plate sealer produces repeatable plate seals. With variable temperature and time settings, sealing conditions are easily optimized to guarantee consistent results, eliminating sample loss. The plate sealer is useful in a variety of laboratories.

Features:

1. Works with a variety of plates and seals
2. Seals plate heights: 9 to 48mm high
3. Adjustable Sealing Temperature: 80 – 200°C
4. Bright, LED display screen with no visual angle limit
5. Precise temperature, time and pressure settings for consistent sealing
6. Compact footprint: only 7.0 inches (17.8cm) wide
7. Automatic counting function
8. The drawer is controlled by high grade MCU. If the drawer is blocked when moving, the drawer motor will automatically reverse. This prevents injury to the user and damage to the unit.
9. Detachable drawer for easy cleaning of the heating platen
10. If the unit is left idle more than 60min, it automatically switches into stand-by (energy saving) mode during which the temperature of the heating element is reduced to 60°C
11. When the unit is left idle for more than 120min, both the display and the heater shut down. Pressing any button will “awaken” the unit.

Chapter 2 Specifications

1. Normal operation conditions:

Ambient temperature: 10°C ~ 35°C

Relative humidity: ≤70%

Power: AC100~120V, 50/60Hz or 220-240V, 50/60 Hz

2. The basic parameters and characteristics

Display	OLED
Temperature setting	80°C - 200°C
Temperature accuracy	1°C
Seal time	0.5s – 10s, 0.1 second increments
Cooling time of heating element	≤2°C, return to normal within 25 seconds
Heating element	Electrical heating tube
Input power	300W
Dimension(D×W×H)	370mm×178mm×330mm
Weight	9.6kg

Chapter 3 Basic Instructions

This chapter introduces the structure, operation keys, and display of the instrument, as well as preparatory work before starting. Please read this chapter before using the instrument for the first time.

1. Structure overview

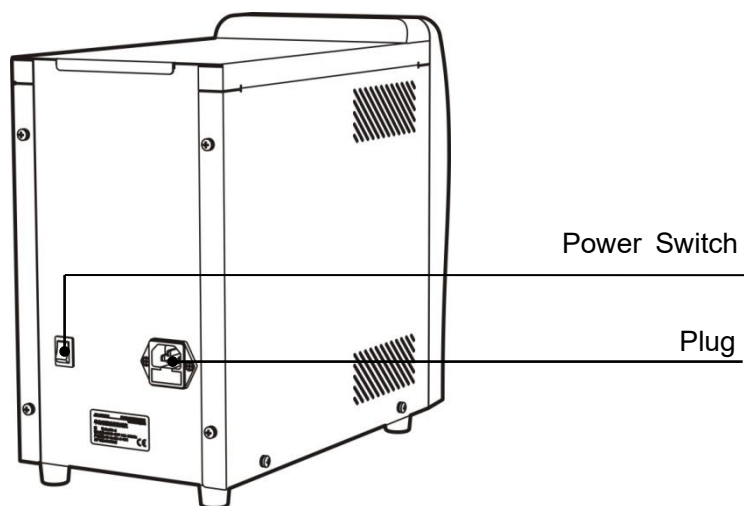
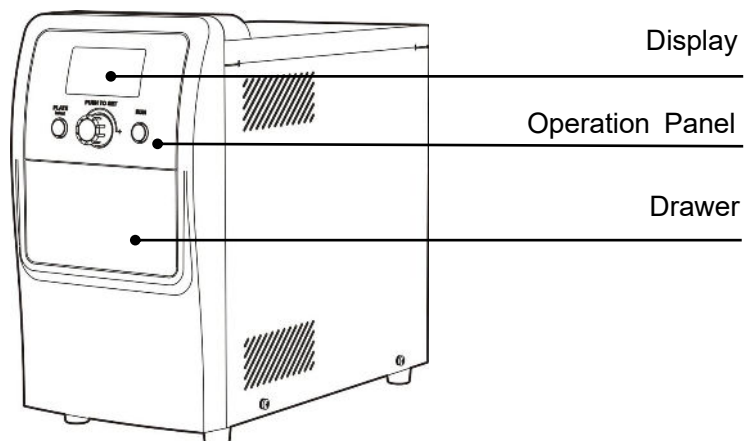

2. Operation panel

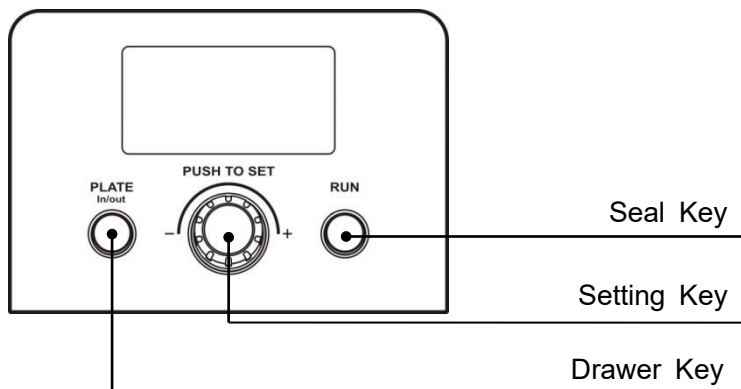

3. Display

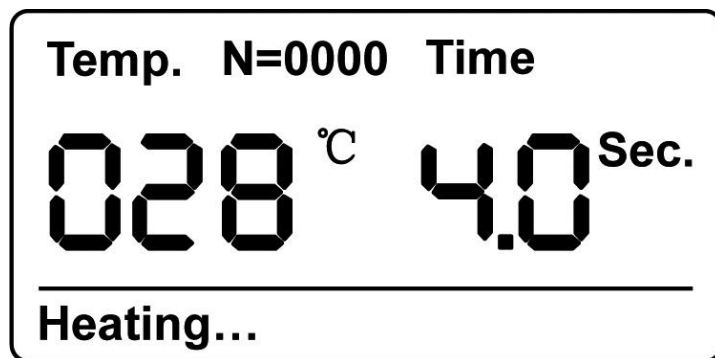

Chapter 4 Operation Guide

1 Setting sealing conditions

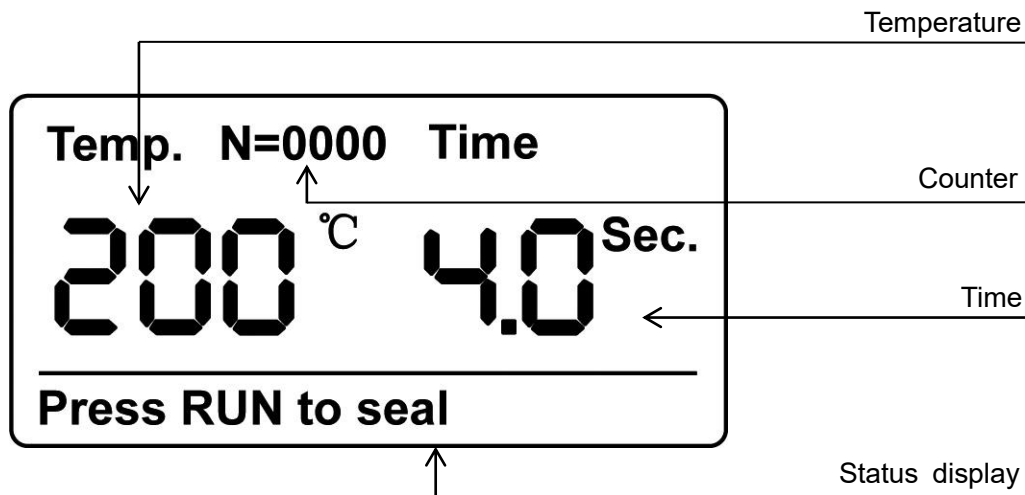

1.1 Setting the seal temperature

Turn the unit on using the power switch on the back of the instrument. The unit will immediately begin heating. To set the sealing temperature, press and hold the press the “**PUSH TO SET**” knob for 3 seconds. When the temperature begins to flash, turn the “**PUSH TO SET**” knob to set the desired parameter. Turning the knob counterclockwise will lower the value and clockwise rotation will raise the value. The settable range is 80° to 200°C.

1.2 Setting the seal time

After setting the temperature, press the “**PUSH TO SET**” knob again. When the time begins to flash, turn the “**PUSH TO SET**” knob to set the desired parameter. Turning the knob counterclockwise will lower the value and clockwise rotation will raise the value. The settable time range is 0.5 to 10 seconds.

Note: If no action is taken for 5 seconds, the chosen values are automatically confirmed.

1.3 Setting the pressure function

Note: Adjust the pressure according to the seal quality (by review of the well trace/indentation after sealing). Raise the pressure if the trace is too light, lower the pressure if the trace is too deep.

Press “**PUSH TO SET**” knob and “**PLATE In/Out**” button simultaneously for 3 seconds. This will open the pressure screen. Turn the “**PUSH TO SET**” knob to adjust seal pressure – counterclockwise reduces pressure and clockwise increases pressure. The value can be set from 1 to 5. The factory default setting is 3.

Appendix: Normal seal temperature and time

No.	Item	Seal condition setting	No.	Item	Seal condition setting
1	Most Clear-Seals	170°C, 2.5S	3	Pierce-Seal	180°C, 4S
2	Most Foil Seals	175°C, 3S	4	Al foil-Seal	180°C, 4S

Note that sealing efficiency will vary depending on the type of plate/seal used. The above are listed as a guide. Actual temperature/time may need to be adjusted.

2 Seal operation

After setting the sealing parameters, the machine is ready for operation. A tone will sound when the set temperature is reached.

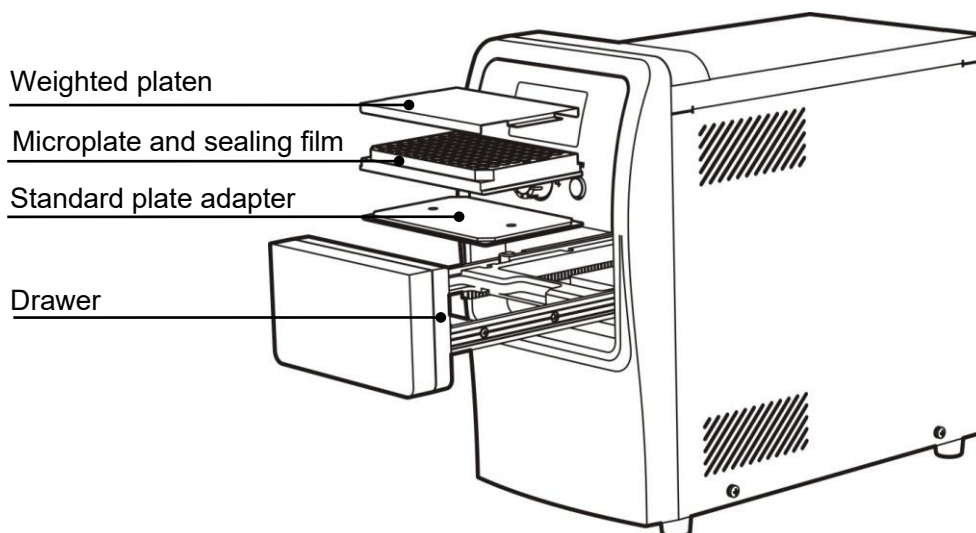

2.1 Press “PLATE In/Out” button to open the drawer. Place the appropriate plate adapter in the drawer. The microplate can then be placed on the adapter followed by the sealing film. If needed, the weighted platen should then be placed on top (recommended). Note: If you use the weighted platen, sealing times should be increased by 1 second.

2.2 Press the “**RUN**” button to close the drawer and activate the sealer. Once the seal is made, the drawer will open automatically. The unit is then ready to seal another plate.

Note: The plate sealer will not operate until heating plate has reached the set temp.

2.3 When finished, press the “**PLATE In/Out**” button to close the drawer. Turn off the unit with the switch on the back. (Always ensure the drawer is closed prior to powering off.)

3 Cleaning the heating plate

3.1 If there is residue on the heating platen from sealing plates, it can affect normal operation of the instrument and the heating platen should be cleaned as follows:

3.2 Press “**PLATE In/Out**” button to open the drawer. Turn off the power using the switch and unplug the plate sealer from the power source.

3.3 Press the tab located on the left side drawer rails (see below) and pull out the drawer outward firmly and evenly.

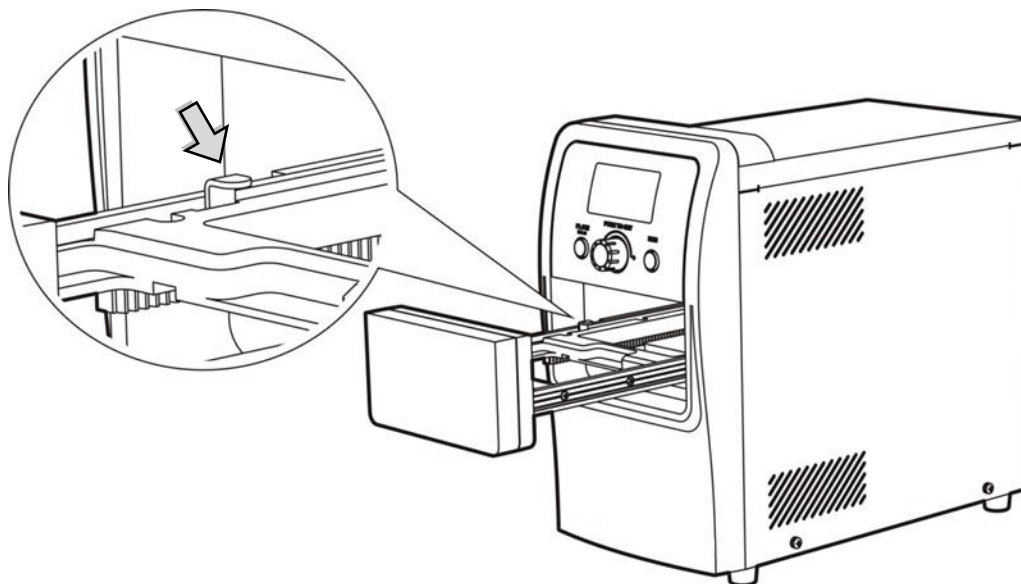

3.4 Clean the residue from the heating platen with a soft cloth. The cloth can be moistened with alcohol if required. Be sure that the platen has cooled to ambient temperature before cleaning,

Note: Do not scrape the platen with any hard or tough tools as this can cause damage.

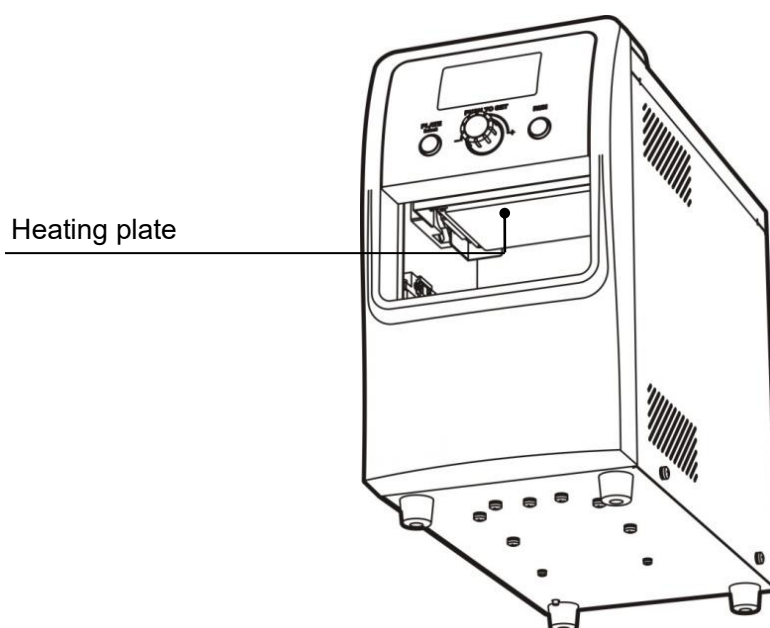

3.5 After cleaning the plate, replace the drawer by lining up the rails with the sliding blocks located inside the unit and sliding the drawer back in place. Press the drawer firmly to close.

4 Additional important information

4.1 “No plate” alarm

If sealing is attempted without an adapter/plate in place, the unit will beep, the door will open and the screen will show “No plate”.

4.2 Stand-by mode

The unit will enter “stand-by” mode if not used for more than 60 minutes. The temperature of the plate will lower to 60°C. Press any button to warm up the unit back to the set temperature.

The unit will enter “Power-down” mode if not used for more than 120 minutes. The display will turn off, and power to the heater will shut off. Press any button to warm up the unit back to the set temperature.

4.3 Power-off protection

In the event of a power failure when the unit is in operation, the motor will stop. When the power is restored, the unit will reset.

4.4 Automatic counting function

The plate sealer features an automatic counter. The counter is located at the top of the display and will increase by one for each plate sealed. The counter can be reset to zero by pressing the “**PUSH TO SET**” knob for 10 seconds.

Chapter 5 Troubleshooting Guide

Problems and actions

No.	Common problem	Possible cause	Action(s)
1	No display after power on	No power	Check power supply and that the unit is plugged in properly
		On/Off switch broken	Change switch
		The fuse is broken	Change fuse (5X20 250V 4 A)
		Others	Contact the supplier
2	Display “ Err001 ” and alarm tone sounds	Over-temperature	Contact the supplier
3	Display “ Err005 ”, “ Err006 ”, and alarm tone sound	Open or short circuit of temperature sensor	Contact the supplier
4	Display “ Err601 ” and alarm tone sounds	Motor locked	Contact the supplier
5	Display “ Err405 ” and alarm tone sounds	The upper micro-switch is broken	Contact the supplier
6	Display “ Err412 ”	The lower photo electric switch is broken	Contact the supplier
7	Display “ Err411 ”	The upper photo electric switch is broken	Contact the supplier
8	Display “ Err408 ”	The out photo electric switch is broken	Contact the supplier
9	Display “ Err407 ” and alarm tone sounds	The enter-photo electric switch is broken	Contact the supplier
10	“ No plate ” displayed and alarm tone sounds	No /adapter or incorrect placement	Replace the microplate
11	Instrument cannot run	Control board issue	Contact the supplier
		Motor issue	
12	Abnormal running noise	Wrong guide rail installed	Contact the supplier
13	Buttons don't work	Plug connector loose	Contact the supplier
		Button broken	

Annex: Wiring Diagram

(for reference only, users won't be informed if there is modification for this diagram)

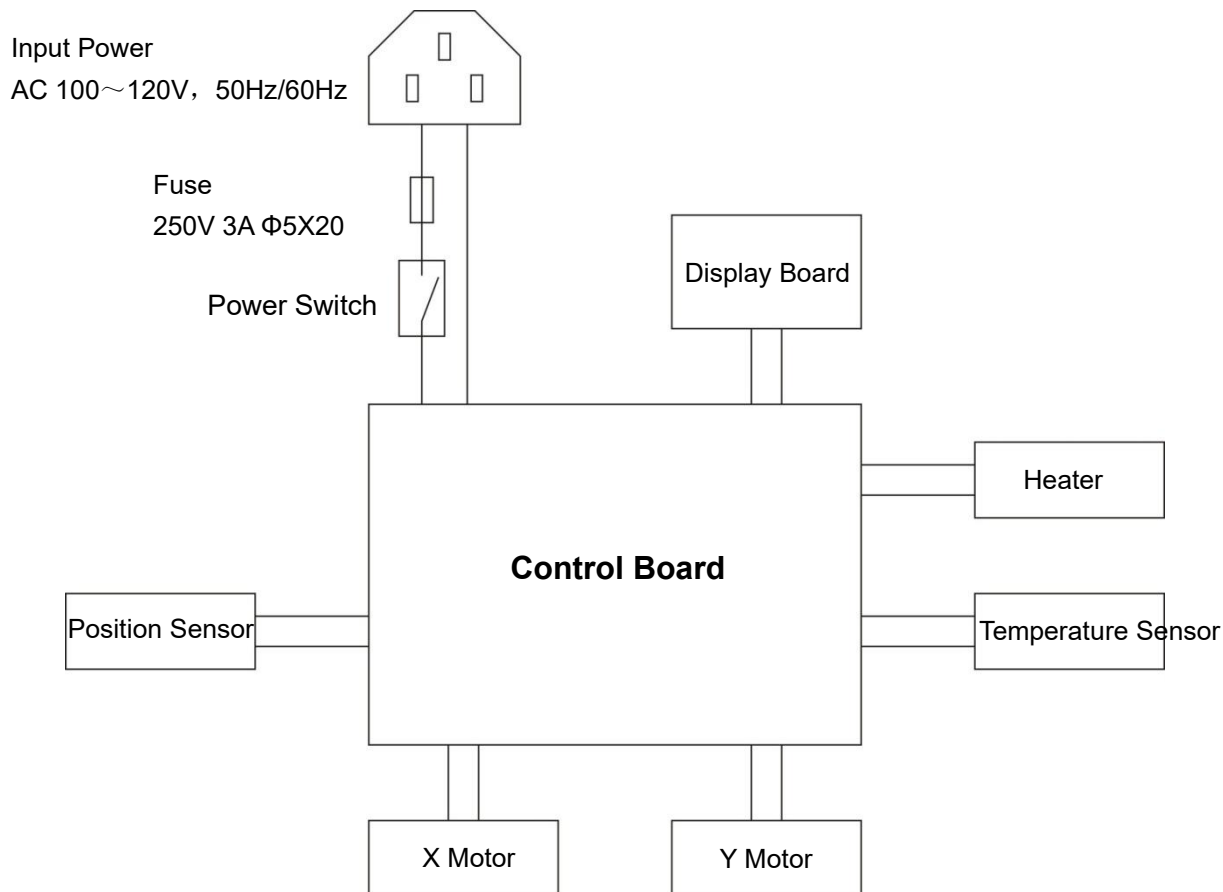

Notes

